



www.calscan.net
780-944-1377

"Keeping the Sky Blue"



Modernize

Your Separator Design to

Zero Emission

with the Bear Fail Safe System



Zero Emission Prototype Separator 2009

First Upgrade your Actuator



Traditional Methane Powered Actuator

Bear BA-15L Solar Powered Actuator

Your Valves Stay the Same
Just add our Solar Ready
Bear Electric Actuators

Now Protect it



From Power and RTU Failure
with the Bear UPS and
Fail Safe Controller

Bear Benefits:

Environment:

- **ZERO EMISSION** for the life of the well
- Compliance with BC 2021 Regulations:
OGC 286/2018 Section 52.05 - Pneumatic Devices
- Compliance with Alberta 2022 Regulations:
AER Directive 60 Section 8.6.1 - Vent Gas Limits for Pneumatic Devices

Finance:

- Carbon credits available in Alberta until 2028 for new and old installations (green & brown field)
- Alberta Government Incentive:
MTIP for brown field projects, 50% cost recovered
- Increases gas sales per year

Operations:

- Uses existing valves and controls for easy installation
- Safer operating conditions for field personnel by eliminating venting of dangerous well gases such as H₂S
- Eliminate maintenance issues with pneumatic instrumentation and actuators using wet/sour/dirty fuel gas

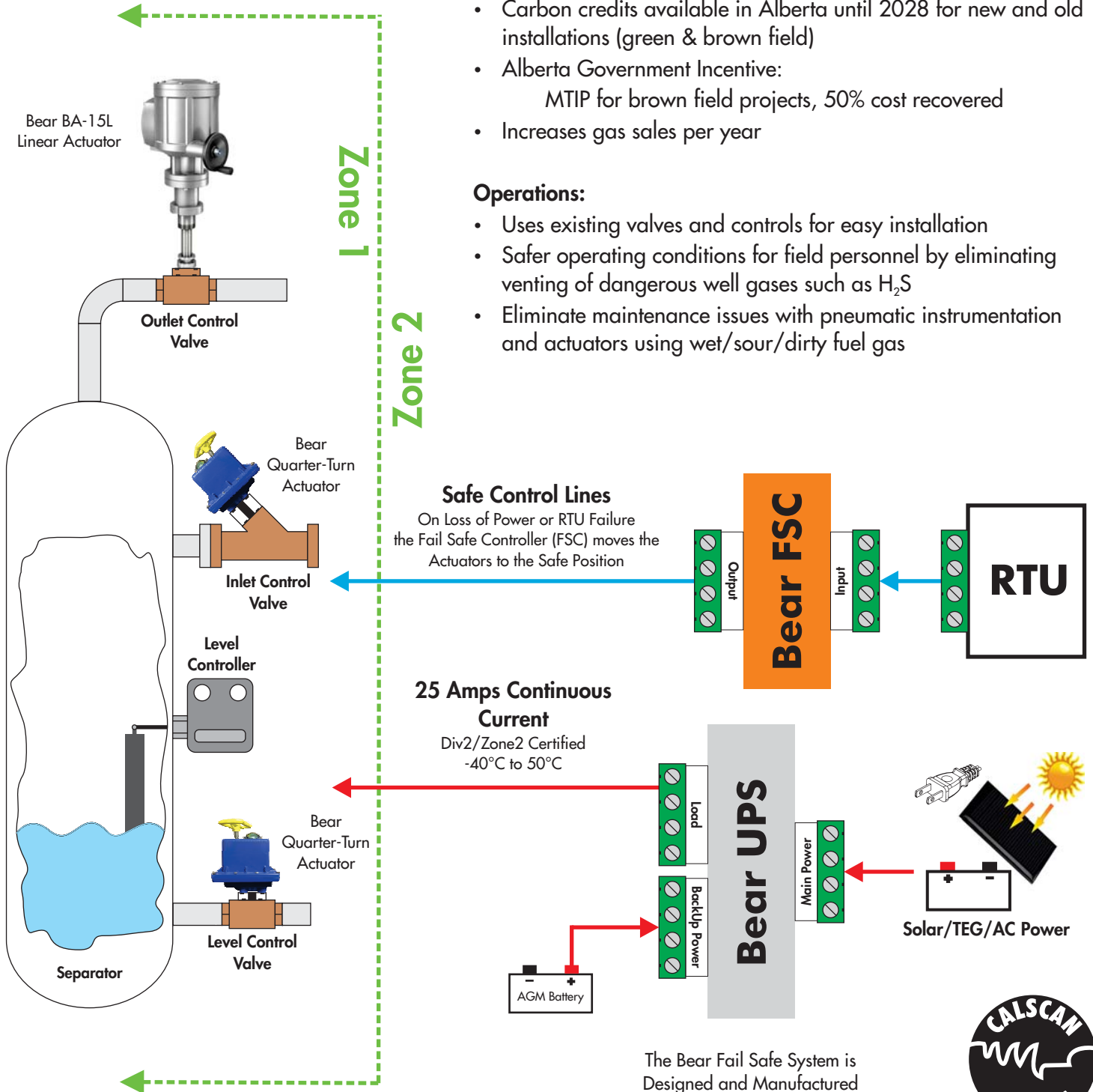

The Bear Fail Safe System is Designed and Manufactured in Alberta by Calscan Solutions



www.calscan.net
780-944-1377